

Kingdom of Cambodia
Nation Religion King



Program Overview of SCRH/DFID



Departmental Director Meeting

28 September 2005

MOEYS Brief: Strengthening Cambodia's Response to HIV/AIDS

Introduction

- Strengthening Cambodia's Response to HIV/AIDS is a multi-sectoral program.
- Support is being provided for National AIDS Authority (NAA), National Centre for HIV/AIDS, Dermatology and STD (NCHADS), the Ministry of Education, Youth and Sports (MoEYS) and BBC World Service Trust.

Finance Issues

- Support to MoEYS is US \$ 4.3 million over 5 years (2003-2008).
- UNDP administers the program funds. UNDP policies, guidelines and rules apply to the management of funds and the provision of services.
- Funds are disbursed against annual Work plans agreed annually by the Program Steering Committee Meeting
- The funds will be disbursed quarterly through an impress account, with the amount spent in the previous quarter being released in the next quarter
- Financial management is conducted by a task team in the Department of Finance.

MoEYS: Program Overview

- The program is managed and co-ordinated through a core team drawn from ICHA, and led by the Secretary of State, MoEYS.
- DGE is responsible for the institutional and technical management of the program.
- DGAF is the responsible for the financial management of the program
- The whole program is implemented through existing MoEYS structures by MoEYS staff with TA support – it does not have a parallel Project Implementation structure.

Management Structure

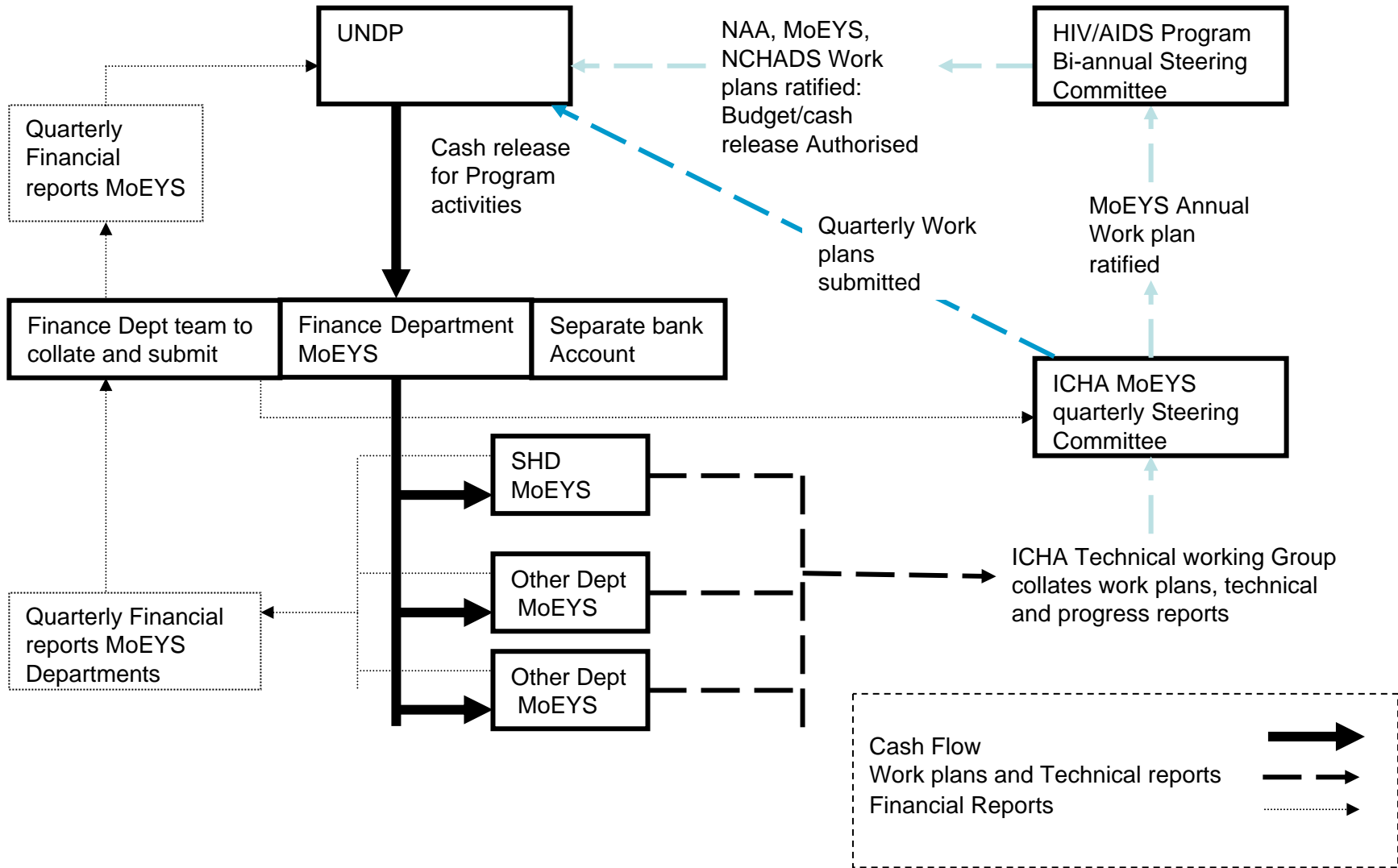

Program Strategies

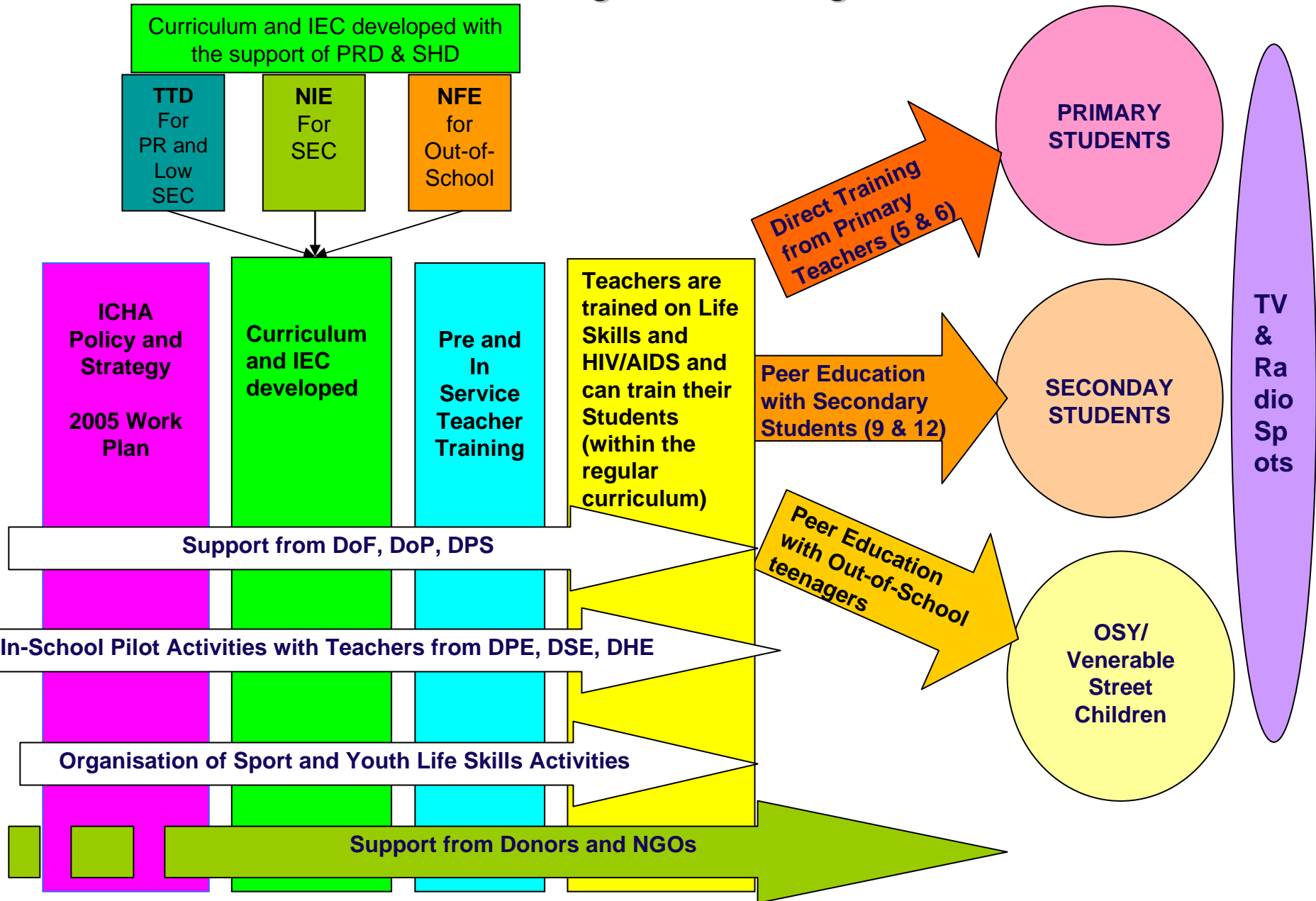

Strategic Program

The MoEYS/Strengthening Cambodia's Response to HIV/AIDS program (supported by DFID) is based on 2 main Components:

- ***Mainstreaming (ICHA Secretariat and MoEYS Departments)***
- ***Life Skill for HIV/AIDS Education Program (Sec; Pri; OSY & VSCP)***

Mainstreaming Program

This program :

- Are implemented by 15 departments /institution in Moseys.
- Are focused in capacity building and strengthening department/institution staff.
- Are integrated through any department/institution events.

Life skill for HIV/AIDS Education Program Plan

Province and Time Frame	2005 Pilot Phase	2005/06 Academic Year	2006/07 Academic Year
1. Siem Reap	✓	✓	✓
2. Kampong Speu	✓	✓	✓
3. Kampong Cham		✓	✓
4. Kampong Thom		✓	✓
5. Kampot		✓	✓
6. Koh Kong		✓	✓
7. Kampong Chhnang			✓
8. Otdar Meanchey			✓
9. Preah Vihear			✓
10. Sihanoukville			✓
Phnom Penh *		✓	✓

* *Phnom Penh will only cover vulnerable/street children in Year 1 and possible extension to other provinces in Year 2*

What is the new “Life Skills for HIV/AIDS Education Program”?

- A **Life Skills** approach is being used to introduce HIV/AIDS Education to Students and Out-of-School youth,
- **Classroom** teaching on Life Skills for HIV/AIDS will be delivered in Primary Schools (grade 5 and 6),
- A **Peer Educators approach** will be used for Secondary students (grade 9 and 12) and for Out-of-School Youth (13 to 19 years old),
- A Peer Education approach will be **tested** in a few Primary Schools,
- In Phnom Penh, **Street Children** will also be covered by this Program.

